

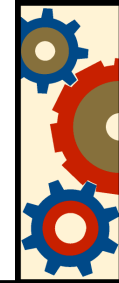

The root name servers and DNS anycast

João Damas

Agenda



- DNS and the place of the root servers
- Root servers vs root zone
- Root server operators
- Anycast
 - Types of anycast
- F root anycast
- +Raices



DNS



- A tree-like lookup system
- Converts human readable tokens into machine usable identifiers
- Root servers are the entry point to the system
- Caching is used throughout to avoid repetitive queries



DNS resolution process

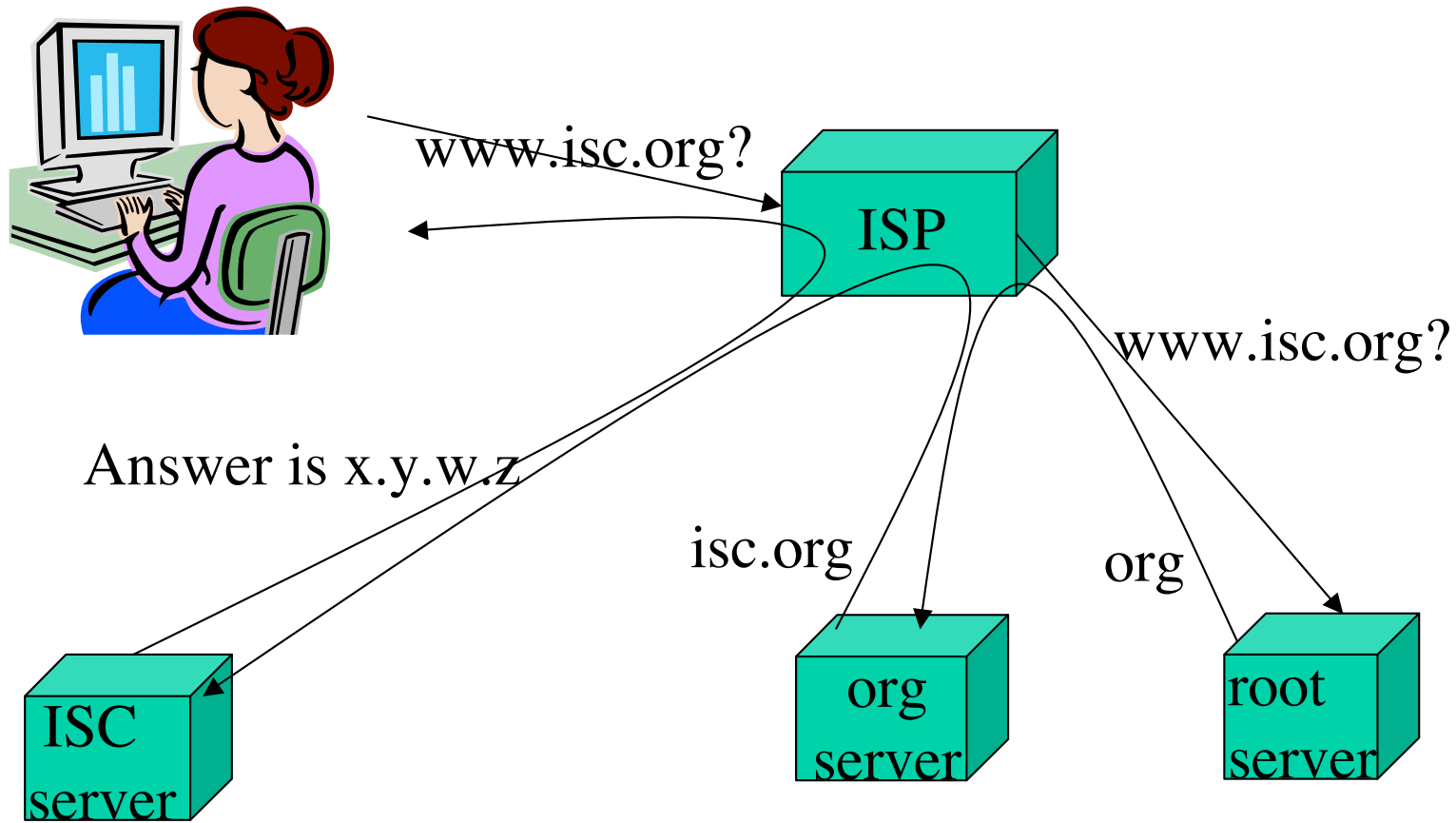
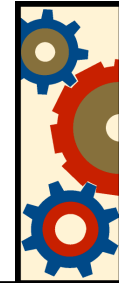

Caching

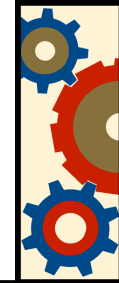

- Optimisation to reduce number of required queries
- Consistency of information is managed through the use of TTL values



Root servers vs root zone



- root servers
 - Provide the service
 - Currently limited to 13 distinct entries in the list
 - a.root-servers.net,...,m.root-servers.net
 - Purely technical role. Responsibility of the root server operators
- root zone
 - Is the information itself
 - Created by IANA (currently an ICANN function)
 - Distributed by Verisign to all root servers.



The root server operators



12 different professional engineering groups
focused on

- Reliability and stability of the service
- Accessibility to all Internet users
- Technical cooperation
- Professionalism



The root server operators (2)



- The operators are not involved in:
 - Policy making
 - Data modification
 - Publishers, not authors or editors.
- The operators are involved in:
 - Careful operational evaluation of suggested technical modifications
 - Making every effort to ensure stability and robustness



The root server operators (3)

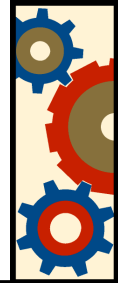

One of the strongest points of operators is diversity

- Diversity of organisational structure
- Diversity of operational history
- Diversity of hardware and software in use



The root server operators (4)



The other strong point is cooperation and coordination

- Within the diversity, cooperation takes place at industry meetings.
- There is permanent infrastructure to respond to possible emergencies
- Coordination within established Internet bodies (RSSAC within ICANN)



Anycast IP services

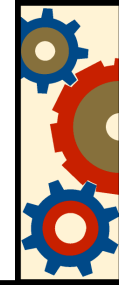

- Traditionally IP services were
 - Unicast
 - Multicast
- Anycast is a third option
 - Multiple instances respond to the same IP address



Anycast typology

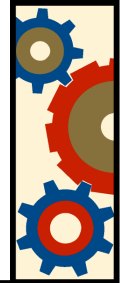

- Local
- Global
- Owned
- Unowned



Local anycast



- Clustering or local load balancing
 - Could be done with a Layer 4 switch
 - Introduces additional points of failure
 - Better to use standard routing equipment which is necessary anyway
 - Use CEF (Cisco) or equivalent Juniper equal-cost-multipath routing. Hash based forwarding
 - OSPF, well known routing protocol
 - Works well with TCP and UDP



Global (distributed) anycast



- Use BGP to announce the same destination from various places in the Internet
- At each point BGP routers chose the “closest” destination among all the visible ones
- Very good for UDP services
 - TCP services may suffer if routing decisions change between successive packets (short live-long lived sessions)



Global (distributed) anycast (2)



- Additional BGP parameters can be used to control distribution of service
 - NO_EXPORT community allows definition of service regions
- Very flexible
 - Combination of globally visible servers with limited visibility servers allows for robust service



Owned anycast

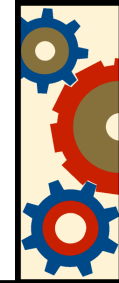

- A prefix is announced at several places
- Origin AS can be the same or not
 - Using the same origin AS clarifies usage policy for the prefix
- Authorisation for use of the prefix and the AS is well defined



Unowned anycast



- Prefix and AS number are authorised for use by many interested parties
- AS112 project
 - <http://www.as112.net>
 - Blackhole DNS traffic requesting reverse resolution for RFC 1918 address space



F root anycast - why?



- Increase survivability of the root servers system and of ISP network
 - Cope with DDoS attacks, provide a means of measuring them by partitioning the total traffic volume
 - Cope with network partitions
- Increase performance of local resolvers
- Bring service closer to regions who have been far away from root servers



F root anycast - how

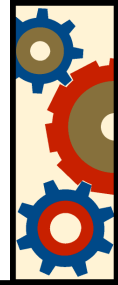

- In cooperation with local sponsors that are willing to work with ISC to bring the service to their communities or customers.
- ISC maintains administrative control and responsibility over the service



F root anycast - how

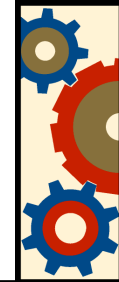

Each F root node advertises the F root /24 and AS number

Each F root node has its own unique AS and unique /24

Management versus service

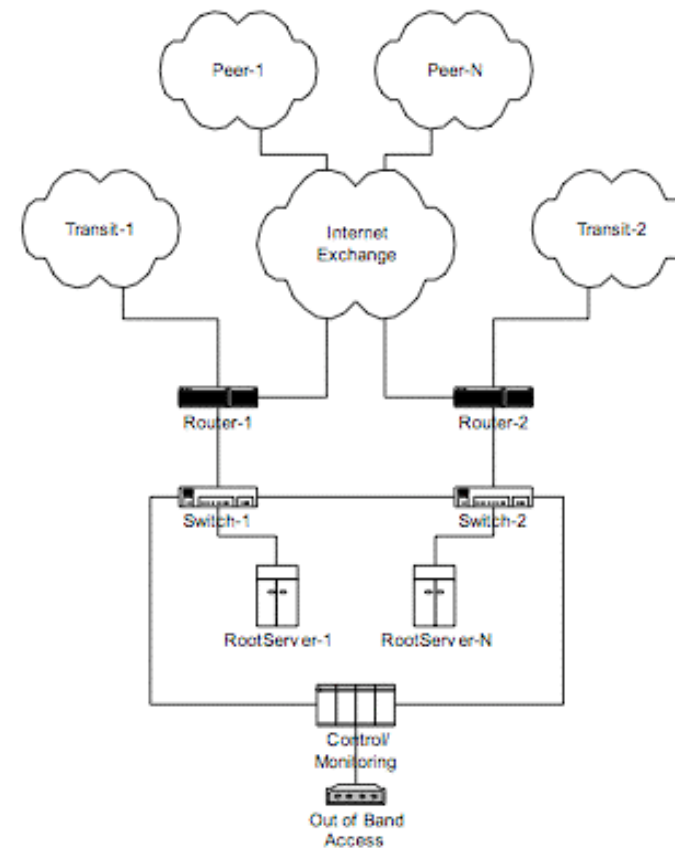

F root anycast - where



- Preferably at IXPs or NAPs as they give the broader access to all the regional networks
- We don't F root to be used as a bargaining chip between ISPs, just to serve the community



Other root servers



- I and K use similar setups to F
- J is anycasted in most of the same places that host the gtld-servers.net servers
- C is anycasted within Cogent
- Others are studying their next steps
- Look at <http://www.root-servers.org> for more information



Antes de anycast

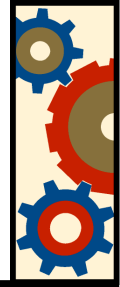

6 Outubro de 2004

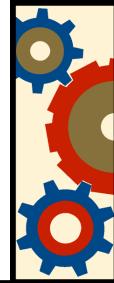

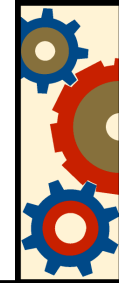

- Agreement between ISC and LACNIC to pursue the installation of up to 7 anycast instances in the LACNIC region
- LACNIC has a major role in developing the Internet in the LAC region
- Goal is to improve service for the region
- Contact LACNIC for more information





Questions?

<http://www.isc.org>

Joao_damas@isc.org